

GUILDEN MORDEN PARISH COUNCIL

(South Cambridgeshire District)

NOTICE OF MEETING

The Meeting of the Parish Council will be held in the Village Hall on Monday 21 September 2015 at 7.30pm

The Public and Press are cordially invited to be present

All members of the Council are hereby summoned to attend for the purpose of considering and resolving upon business to be transacted as set out below

LG  Signed, Gail Stoehr, Clerk, 15/09/15

AGENDA

Comments and observations from members of the public and from the County & District Cllrs

- 1. To receive apologies for absence and declarations of interest**
 - 1.1 To receive written apologies and reasons for absence
 - 1.2 To receive declarations of interests from councillors on items on the agenda
 - 1.3 To receive written requests for dispensations (if any) and to grant any requests as appropriate
- 2. To approve the minutes of the last meetings on 20 July and 17 August 2015**
- 3. Matters arising from last or previous meetings carried forward for discussion/decision**
 - 3.1 (3.2) Relocation of assets from Barry's Barn ^(GH, JT)
 - 3.2 (3.2) New Financial regulations ^(GH, JT)
 - 3.3 (3.7) Use of church grounds safety to consider any works required
 - 3.4 (4.2) Cemetery memorial safety to consider quote and advice from Willingham Memorials
 - 3.5 (6.5) Football Club request for a S137 grant for additional seating on the recreation ground
- 4. Financial, procedural and risk assessment matters**
 - 4.1 To receive the financial report and approve the payment of bills
 - 4.2 Risk assessments including play inspections and tree reports
 - 4.3 To approve draft S137 application form
- 5. Members, Working Groups items for discussion and decision**
 - 5.1 Request from residents for "No smoking" signs in children's play area ^(JT)
- 6. To consider correspondence/communications received**
 - 6.1 Hibbitt and Sons request for memorial approval for a flatstone
 - 6.2 CCC Minor Highways Improvement Scheme invitation to bid
 - 6.3 CCC Draft Cambridgeshire Flood and Water Supplementary Planning Document
 - 6.4 CCC Rights of Way Improvement Plan review consultation
 - 6.5 SCDC consultation on moving to all out elections
 - 6.6 Police invitation to Modern Day Slavery Summit on Saturday 17th October 2015
 - 6.7 CCC Streetlighting consultation
 - 6.8 Resident – complaint Vineyard grass cutting promoting weed growth
- 7. To consider planning and tree works applications and decision notices received since the last meeting**
 - 7.1 Planning applications received ^(DT, GD)
 - 7.1.1 S/1773/15/FL – 72 High Street – Conversion of double detached garage to annex
 - 7.1.2 S/2098/15/FL – 51 New Road – Proposes single storey rear extension to living room, side & rear extension to annexe to create additional bedroom with ensuite
 - 7.1.3 S/2230/15/PH – 38 Fox Hill Road – Notification of a proposed larger home extension for a 6m rear extension
 - 7.1.4 S/2156/15/FL – Rectory Farmhouse, 37 New Road – Single storey rear extension
 - 7.2 SCDC Decisions and appeal notifications
 - 7.3 Tree works applications
- 8. Items for the next agenda and closure of meeting**

GULDEN MORDEN PARISH COUNCIL
Clerk Report to the Parish Council meeting on 21 September 2015

County Councillor's report attached.

1. Apologies – None at the time of writing.
 3. Matters arising
On enquiry the Clerk was told that the materials for Ridgeons cost more than anticipated but were needed to complete the job.
 - 3.2 New Financial Regulations – attached.
 - 4.2 Risk assessments including play inspections and tree reports
 - 4.3 To approve draft S137 application form
Attached.
 - 3.5 To consider request for S137 grant for the Football Club
Cllr Dellar wrote to the Football Club on 22 July as follows:
Your request for additional seating was discussed at the Parish Council meeting on 20th July and the council agreed in principal to allow this provided they can approve the exact plans beforehand, and that your club will bear the full cost of installation and maintenance. With regard to spiking the pitch, the Parish Clerk has details of the free use of a verti-drain machine if you are interested. The Football Club has responded as follows:
Thank you and the council for your response. With regard to the seating: Do you have any rough idea as to the cost of maintenance? As clearly we would have to insure that if the club folded that some provision would be allocated so as the cost would not be left to the council. Would the responsibility of maintenance include liability if someone was hurt on the seat, for example if it was damaged and not yet repaired, or would this be included under the recreation ground liability? Providing we can get a sponsor we would, of course, expect the council to see and approve the plans beforehand. As a general principle I think we would like any seating to be under the trees such as the present one. Would it be preferred that any seating be in the same or similar style as to the present seat dedicated to the memory of Princess Diana? With regard to the verti-drain machine: Yes, thank you very much we would very much like details of the free use of one of these. We advised that at this time the ground is too hard so it might be quite a few weeks before we could expect to be able to use such a device.
- Other for info only
- (6.3) Three Tuns. SCDC has replied “We have received the same complaints from neighbouring residents as well. The Councils Conservation Officer went out to the site a few weeks ago to assess the impacts. However, found at this stage the impact of the overgrowing shrubs and saplings was not server or large enough to effect or undermine the historic fabric of the building. As such officers were advised that no action could be taken at this stage. However, officers at the Council will continue to monitor the situation until the building is occupied. The Parish Council are encouraged to keep advising officers of the state of the site so we can keep up to date records in the event action can be taken in the future. “
- 4.1 Finance report – attached.
 - 4.3 S137 application form – draft attached.
 - 5.1 Request from residents for “No smoking” signs in children’s play area
Two parishioners who are doctors/a chest physician have asked whether signs could be put up in the children's play area asking people not to smoke in the enclosed area.
 6. To consider correspondence/communications received

- 6.1 Hibbitt and Sons request for memorial approval
Attached. The memorial does not comply with current cemetery regulations which only permits flatstones on ashes plots.
- 6.2 CCC Minor Highways Improvement Scheme invitation to bid
Cambridgeshire County Council is once again delivering its Local Highway Improvement (LHI) initiative, which has recently been updated, following a review conducted by County Councillors. Please find attached the new application form and supporting guidance document for applicants. It would be appreciated if you could also circulate this information to any groups in your community that you think may be interested in this initiative.
Please note that the closing date for LHI 2016/17 application forms is Monday 2nd November 2015.
- 6.3 CCC Draft Cambridgeshire Flood and Water Supplementary Planning Document
I am emailing to inform you that we are consulting on the draft Cambridgeshire Flood and Water Supplementary Planning Document (SPD). The draft SPD has been developed by Cambridgeshire County Council (as Lead Local Flood Authority) in conjunction with the Local Planning Authorities (LPAs) within Cambridgeshire, and other relevant stakeholders.
Once adopted the SPD will support the implementation of and provide guidance on flood risk and water related policies in the Local Plans of Cambridgeshire planning authorities:

- Cambridge City Council
- Cambridgeshire County Council
- East Cambridgeshire District Council
- Fenland District Council
- Huntingdonshire District Council
- South Cambridgeshire District Council

The SPD has been subject to Sustainability Appraisal, Habitat Regulations Assessment and Equality Impact Assessment, and is supported by a Consultation Statement.

Adoption and Maintenance of Sustainable Drainage Systems in South Cambridgeshire – this additional document relates to South Cambridgeshire only, and provides additional information on the adoption and maintenance of sustainable drainage systems in South Cambridgeshire that should be read alongside the draft SPD.

The consultation period runs from 9am on Friday 4 September to 4.30pm on Friday 16 October 2015.

How to View the Documents and Make Comments

The consultation documents are available to view online at:

<http://consult.huntingdonshire.gov.uk/portal/pp/spd/fw>

Paper copies of the documents are also available to view at each Council's offices – details are provided in the Consultation Statement.

Comments can be made:

- Online: <http://consult.huntingdonshire.gov.uk/portal/pp/spd/fw> [this is the Councils' preferred method, please contact Huntingdonshire District Council on 01480 388424 if you have any queries relating to making comments using this system]
- By email to: localplans@huntingdonshire.gov.uk
- By post to: Planning Policy, Huntingdonshire District Council, Pathfinder House, St Marys Street, Huntingdon, PE29 3TN.

Please be aware that any representations made on these documents will be available for everyone to view, including your name and the company or organisation you represent regardless of how they are submitted, although contact details will not be made available. Following this period of consultation, we will assess any comments made and may make modifications.

If you need any further information, please feel free to contact Cambridgeshire County Council's Growth and Development Team on 01223 706574 or email

GrowthDevelopment@cambridgeshire.gov.uk

Yours faithfully

Tanya Sheridan

Head of Growth & Economy
Cambridgeshire County Council

- 6.4 CCC Rights of Way Improvement Plan review consultation –
Cambridgeshire County Council's Rights of Way Improvement Plan (ROWIP) was adopted in 2006 as part of the Cambridgeshire Local Transport Plan 2006-2011. The Plan was formulated following considerable research, data gathering and extensive public and stakeholder consultation with the Local Access Forum playing a key part in the plan's development. The Plan is well used and has been invaluable in, helping to bring about improvements to the rights of way network and enhancing countryside access.
The Draft Rights of Way Improvement Plan provides an update to the ROWIP, in line with the requirements of the Countryside and Rights of Way Act 2000. This update summarises the progress made since the ROWIP was adopted in 2006 and sets out future challenges for rights of way and countryside access to 2031 in the form of updated Statements of Action. This draft update to the ROWIP will form part of the third iteration of the Local Transport Plan, which is known as LT P3.
The draft updated plan can be viewed on the County Council's website
- Comments are invited on the draft documentation during the consultation period which runs until 21st October 2015.
All comments received will be taken into account when the draft document is finalised for publication in November 2015.
- 6.5 SCDC consultation on moving to all out elections - Attached.
- 6.6 Police invitation to Modern Day Slavery Summit on Saturday 17th October
To tackle this problem the Chief Inspector has organised a Modern Day Slavery Summit on Saturday 17th of October 2015, 10:00am in the council chamber of SCDC.
- 6.7 CCC Streetlighting consultation – attached.
- 6.8 A complaint has been received from a resident about the cutting of the Vineyard, that it is not cut properly and properly rotated which encourages weeds including hemlock to grow.
- 7.2 SCDC Decision notices - Are available on the Planning Portal or from Cllr Thorpe.
- 7.3 Tree works applications – none received at the time of writing.
SCDC has advised that as a temporary measure due to the high number of applications for a short period of time, it will only be consulting the Parish Council on applications for major tree work or applications for felling substantial trees in Conservation Areas.
However, it will continue to consult the Parish Council as normal on all applications for works to TPO trees.

County Report September 2015
Councillor Adrian Dent

Local Issues

August saw me unfortunately unavailable due to illness

1. Straw in the gully's have caused a few issues in some villages, with some people in a few of the villages, unfortunately it is that time of year, best advice is if you see a drain covered brush it off where possible and report to highways.
2. Recent bad weather saw lesser flooding this time.
3. In Guilden Morden the issue of the Broadband trunking in front of the shops has been addressed and rescheduled.
4. Access to the Ski Club via Guise Lane, as of yet no application formally made.
5. Speeding in a number of places has raised its head again, namely the A1198 through Kneesworth, Whaddon Gap being reiterated and narrowness of the road for farm vehicles.
6. Speed Control bumps are to be placed in Litlington in the near future on the Bassingbourn Road I have to attend a meeting on 9th of September in Huntingdon to give this the go ahead
7. Solar Farms are still the hot topic with the Tadlow Croydon, Wrestlingworth Area of particular concern.
8. Also solar farm cable access through two county farms in Whaddon have raised one or two issues which I am following up on.
9. Odsey Junction, I have seen no further information regarding issues on-going here
10. Kerb dropping in Brook Road Bassingbourn is not being done because of budget
11. Broadband is still set to be in place for September to December of this year for most of the remaining villages in the Bassingbourn division.
12. I have had meetings with the MOD and DIO awaiting designation of use of the Barracks I am advised that the Army are pushing to have a British training base there. Most likely no movement until the new year.
13. School crossing Patrol in Bassingbourn will be in place for September.
14. There have been a number of issues of pathways and verges being overgrown, with the hiring of a new contractor a full cutting is under way, some minor issues on what they cut but seems to be progressing
15. Issues with some of the pathways in Frog End Whaddon. Are all part of above issue mentioned.

KEY ISSUES –September 2015

ECONOMY, TRANSPORT AND ENVIRONMENT SERVICES

Street Lighting

The street lighting replacement programme is on schedule to be completed by the end of June 2016. As at the end of June 2015, 40,032 street lights had been upgraded, which represents 73% of the programme.

Works to upgrade the street lighting in Cambridge and Huntingdon have commenced and will be ongoing throughout August. Works are due to start in Ely shortly, together with 21 villages including Littleport, Soham, The Stukeleys, Cheveley, Dullingham, Great and Little Wilbraham, Guyhirn, Pymoor, Horningsea, Stapleford, Stetchworth, West Wrattling, Wilburton, Wimblington, Witcham, Woodditton, Wyton, Castle Camps, Cottenham and Fen Ditton.

Contact: Jamie Cooke – Commission Manager (Highways and Transportation)
jamie.cooke@cambridgeshire.gov.uk

Ely Southern Bypass

A consultant (WYG) has been appointed and is currently preparing the contract to design and construct the bypass. WYG has looked carefully at the process required to minimise and apportion risk, and to control costs appropriately, and has advised that the procurement programme is extended to facilitate additional engagement with potential contractors during the tender process. On the basis of the suggested extended tender period, the completion of the scheme, subject to agreeing a contractor's programme, would be spring 2018 but further work may bring this date forward. It was discussed at a Project Board meeting held on 13 August 2015.

The draft Compulsory Purchase Order (CPO), Side Roads Order (SRO) and Bridge Order were reviewed by the Department for Transport (DfT) for legal compliance and were published in May 2015. The closing date for objection to all the orders was 30 June 2015. Two objections have been made to the CPO and none received to the other orders. One objection is from a member of the public and the second is from Network Rail (NWR). The former has been made against the general principle of the scheme and its impact on the views of the city and cathedral, an issue that was considered in depth when the planning application approved. The latter is made for NWR procedural reasons. A draft agreement to withdraw the NWR objection, subject to certain conditions of access has already been reached. Although possible, it is not anticipated that the DfT will call a public inquiry to the single objection.

Contrary to initial expectations around devolved Growth Deal funding, further work is required to secure the release of the allocated £16million funds. Release of funds for schemes costing over £20m with more than £10m Growth Deal funding will be subject to meeting DfT requirements and Ministerial sign-off. Exact requirements have been unclear, but the release of funds will be subject to presenting a Major Scheme Business Case. Work to update information and the benefit cost ratio (BCR) to demonstrate the strongest possible case has been undertaken and a draft revised business case has been submitted to DfT to provide the basis for discussion to clarify DfT requirements.

Contact: Brian Stinton - Team Leader (Highways Infrastructure Projects)
brian.stinton@cambridgeshire.gov.uk

Huntingdon Road and Hills Road Cycleway Schemes

Long sections of red tarmac have now been laid on the new cycle lanes on Huntingdon Road and Hills Road; cycle symbols still need to be added to the cycle lanes and double yellow lines to the main carriageways. Lighting column holes have been filled in making passage along the footways easier. On Huntingdon Road, the process of installing two new bus shelters, on the bus boarders at Girton Corner and outside NIAB, will begin in the second half of August 2015. Then the surfacing, markings, full height crossing ramp and footway works in and around the bus stops can be finished. The new bus shelter north of the Perse school on Hills Road will also be put in shortly. In September 2015, the redundant white hatching on the main Huntingdon Road carriageway, east of Girton Corner, will be removed by texture blasting.

Neither Huntingdon Road nor Hills Road are wide enough for separate cycle lanes through the works; multiple signs ask drivers not to overtake cyclists in these sections but many choose to do so; as such, officers and contractors felt that allowing space for smaller vehicles to overtake safely was better than narrowing the lane to the extent that all drivers would be required to follow behind cyclists. When the works change to the east side of Hills Road, the shared-use foot/cycleway on the west side will remain open so less confident cyclists have an alternative to cycling through the works on road. This means the completion of the footways on the west side will take place at the end of the works, in spring 2016. The Huntingdon Road works should be finished by November this year, apart from the section between Thornton Road and Lawrence Weaver Road where the new North West Cambridge junction is going in.

Contact: Mike Davies – Team Leader (Cycling Projects)
mike.davies@cambridgeshire.gov.uk

Review of Library Service

The County Council has noted the initial consultation response and is now preparing detailed options for discussion with Councillors and for further public consultation. This further public consultation will take place later in the year, rather than over the summer as previously advised.

Contact: Christine May – Head of Community and Cultural Services
christine.may@cambridgeshire.gov.uk

Summer Reading Challenge – Record Breakers

The Library Service is again supporting the summer reading campaign run by charity The Reading Agency, to encourage all primary school children to take part in this year's Summer Reading Challenge. The Summer Reading Challenge is the UK's largest reading for pleasure promotion and the Council is calling on people of all ages to pledge to use their local library over the summer and help set a Guinness World Record. Last year, the Library Service saw 6,000 children sign up for the Reading Challenge; the Service hopes to break its own record this year by getting even more children taking part this summer. The Library Service receives generous support from a number of local parish and town councils, which is used to pay for additional staffing hours and to fund events and activities to support the challenge such as author talks, animal handling and craft sessions. Local branches of Cambridge Building Society have also given financial aid.

Contact: Richard Young – Development Manager: Children and Young People
richard.young@cambridgeshire.gov.uk

Central Library Enterprise Centre Update

At Full Council on 21 July 2015, Councillors agreed to a review of the processes surrounding the Cambridge Library Enterprise Centre proposals. The Highways and Community Infrastructure Committee decided to rescind a previous decision to go ahead with plans for an Enterprise Centre on 26 June 2015.

The County Council's Audit and Accounts Committee has begun a review of the process that the organisation followed when recently considering the proposal to establish an Enterprise Centre. The terms of reference highlight that the review is focused on any improvements that could be made to the process the County Council went through, and is therefore not a review of the merits of the proposal to create an Enterprise Centre or not. As part of the review, the public was asked to submit any information they felt relevant during August.

Contact: Christine May – Head of Community and Cultural Services
christine.may@cambridgeshire.gov.uk

New Archive/ Council Services Hub in Ely

The change of use planning application is now scheduled to be discussed by the County Council's Planning Committee on 10 September 2015.

Contact: Alan Akeroyd - Archives and Local Studies Manager
alan.akeroyd@cambridgeshire.gov.uk

Brasley Bridge Reconstruction, Grantchester

The replacement of Brasley Bridge, a 12m span structure over the River Cam between Trumpington and Grantchester is currently on programme. The reopening date had been delayed to mid-September 2015,

following issues with utilities, unforeseen ground conditions and piling activities. An increase in working hours and weekend working has meant that further time has been clawed back and, if works progress as planned, the County Council hopes to open the new bridge to general traffic by 28 August 2015. Minor highway works will be carried out during the weeks that follow, but they will have minor impact on road users, other than the removal of the temporary footbridge, where a large crane will be required meaning a further 1 day closure (date dependant on utility works).

The new bridge is starting to take shape and the highlight of this month was the installation of the new bridge beams. The contractor is now excavating and preparing for the construction of wing walls at the four corners of the bridge.

Contact: Andrew Preston – Service Manager - Local Projects
andrew.preston@cambridgeshire.gov.uk

Chesterton Station and Busway Extension

The Station application has been approved by the Joint Development Control Committee on 19th August. As part of that decision a planning condition was set that the Network Rail private means of access be established as a cycle and pedestrian access path to the station prior to its opening. This places a requirement on Network Rail to achieve this condition.

The Crown Estate which owns the adjoining Cambridge Business Park is also seeking permission to establish a direct cycle access into the rail station. It is the Councils understanding that this access will only be for workers at the estate and therefore is a private matter between them and the planning authority except if there are any direct impacts on public highway or the Councils asset (for example the guided busway track)

The busway extension itself is now complete, with the site vacated. The cycle and pedestrian routes to Nuffield Road will open as soon as possible. The busway has been secured until it becomes operational.

Contact: Ashley Heller, Team Leader - Public Transport Infrastructure Team
ashley.heller@cambridgeshire.gov.uk

Ring Fort Path, Kings Hedges/Impington

The County Council is planning to improve access between Orchard Park and Impington by building the Ring Fort Path, a new foot/cycleway. On 14 July 2015, the Economy and Environment Committee approved the development and delivery of Option Four. This option has a ramp starting eighty metres south of the A14 Histon roundabout, on Cambridge Road, and heading down the embankment to the back of Orchard Park Skatepark and Ring Fort Road. This option was the cheapest at £200,000 and may allow for a set of steps also to be built near the roundabout to provide the most direct pedestrian route. A geotechnical study will need to be carried out to see whether the embankment is suitably strong, and if it is, then negotiations to secure access across the land and the detailed design will be finalised. On this basis, construction would proceed in summer 2016.

Contact: Mike Davies – Team Leader (Cycling Projects)
mike.davies@cambridgeshire.gov.uk

Green Dragon Bridge

The Green Dragon Bridge over the River Cam is part of a popular walking and cycling route between north and east Cambridge. However, it is narrow with poor visibility and conflict between pedestrians and cyclists occur.

The County Council is working with Cambridge City Council to consider improvements. A public consultation was recently undertaken and the results are being analysed. Possible improvements include parking restrictions on the Chesterton side, an alternative to the 'Cyclists Dismount' signs and widening of the approach ramps. A decision on how to proceed will be taken in the autumn.

Contact: Mike Davies – Team Leader (Cycling Projects)

mike.davies@cambridgeshire.gov.uk

A14 Improvement Scheme

The examination is currently in progress with open floor hearings (public sessions which allow interested parties to give oral evidence to the Planning Inspectors based on their representations on the A14 scheme) and site visits taking place in August and September 2015. Officers provided a response to Highways England's traffic update report on 15 August 2015 and an addendum to the Local Impact Report (due for 2 September 2015). The Planning Inspectorate is required to conclude the examination by 13 November 2015.

A Members Seminar on Local Traffic Impacts was held on 12 August 2015. Members were presented with traffic impacts on local roads in 2035 as a result of the scheme and the position CCC officers have come to on Highways England's traffic modelling. It was felt that while the model adequately represents route changes as a result of the A14 Cambridge to Huntingdon scheme, and relevant local authorities have a good working knowledge of it, the model in question (CHARM3A + LIT) is a suitable tool for assessing local traffic impacts only for the A14 and only subject to extensive operational testing in detailed design.

Officers are preparing to submit comments on Highways England's local traffic impact report on 19 August 2015 and changes to the Local Impact Report 2 September 2015.

Contact: Edward Cheng – Transport and Infrastructure Officer

edward.cheng@cambridgeshire.gov.uk

Wisbech Access Strategy

March to Wisbech Rail

The outline business case and governance for Railway Investment Projects (GRIP) 2 study for March to Wisbech Rail have just been published. The next stage is for Network Rail to review the documents.

Contact: Jack Eagle- Lead Transport and Infrastructure Officer

jack.eagle@cambridgeshire.gov.uk

Growth Deal/ Local Growth Fund (LGF)

The Shadow Local Transport Body Board has been transitioned to the Local Transport Panel, a sub-group of the Greater Cambridge Greater Peterborough Enterprise Partnership (the LEP). A key role of the Panel is to manage the Growth Deal transport programme and make recommendations to the LEP Board for funding decisions on projects. The Panel will meet in its new form in September 2015.

The first project approved for funding is the Peterborough Bourges Boulevard Phase 1 scheme with a £2.1m grant from the Local Growth Fund.

Cambridgeshire schemes being evaluated for funding include:

- Ely Southern Bypass
- Kings Dyke Level Crossing
- Wisbech Access Strategy

Independent technical evaluation, required for LEP and Accountable Body funding decision, is in progress for the Ely and Kings Dyke schemes. In addition, County Council officers are working with the Department for Transport (DfT) to secure approval and release of the £16m competitive element of the Local Growth Fund for the Ely Bypass scheme.

Contact: Elsa Evans – Funding and Innovation Programme Manager

elsa.evans@cambridgeshire.gov.uk

Greater Cambridge City Deal

On the 4 August 2015, the Greater Cambridge City Deal Executive Board considered reports on the Chisholm Trail cycle links, cross-city cycle improvements, and a Smarter Cambridgeshire workstream. The Board approved the proposed route option for the Chisholm Trail, to be subject to public consultation in the autumn. On the cross-city cycle improvements item, the Board approved the choice of priority strategic cross-city cycle schemes in the report, and approved public consultation on those schemes, to be brought back to the Board for consideration after consultation. The Board also approved the establishment of a Smarter Cambridgeshire workstream to explore the possibilities afforded by smart/digital infrastructure and systems in achieving the City Deal partners' objectives. The next meeting of the Joint Assembly is on 16 September 2015, with the next Executive Board meeting on 1 October 2015.

Further information on the City Deal is available at www.greatercambridgecitydeal.co.uk

Contact: Aaron Blowers – Project Manager (City Deal)

aaron.blowers@cambridgeshire.gov.uk

Connecting Cambridgeshire Programme

Women and Broadband

Connecting Cambridgeshire has been awarded a further £49,300 Women and Broadband Challenge funding from the Government Equalities Office to continue providing practical help for women-led businesses to make the most of technology through its Destination Digital project. The award will be used to launch a county-wide roadshow this autumn offering drop-in clinics with digital advice and training for women who want to run their own businesses or to work more flexibly. It will also help businesswomen get better broadband connections to support their work. Find out more at www.destinationdigital.info

Digital Inclusion

Digital inclusion is increasingly important to enable everyone to participate actively in society and to access digital services, products and networks. However, one in five adults in the UK remain offline or lack the basic digital skills needed to realise the benefits of being online.

Connecting Cambridgeshire has contributed to the Government's new [Digital Inclusion Outcomes Framework](#), launched recently as a flexible tool to demonstrate how digital inclusion activities contribute to local priorities and needs. Cambridgeshire's digital inclusion work was featured as a case study in a recent [Government Digital Service blog](#) highlighting Connecting Cambridgeshire for "delivering high quality connectivity which is underpinned by a drive to provide citizens with the basic digital skills to make best use of the internet."

Contact: Noelle Godfrey - Programme Director, Connecting Cambridgeshire

noelle.godfrey@cambridgeshire.gov.uk

CHILDREN, FAMILIES AND ADULTS SERVICES

Cambridgeshire Local Assistance Scheme – CLAS

Cambridgeshire County Council continues to provide a local assistance scheme to help families and vulnerable individuals under exceptional pressure with practical support such as essential household items such as beds and bedding and energy efficient white goods e.g. washing machines, clothing vouchers, food and emergency utility credit vouchers. 100 applications were made for CLAS in June 2015.

http://www.cambridgeshire.gov.uk/info/20164/money_matters/574/cambridgeshire_local_assistance_scheme_clas

Contact: Dee Revens, Project Development Manager
denise.revens@cambridgeshire.gov.uk

Cambridgeshire Local Safeguarding Children Board (LSCB)

The LSCB has a new website, found at: www.cambridgeshire.gov.uk/lscb/
The site is accessible to children, young people and families as well as the professionals working with them.

Contact: Andy Jarvis, LSCB Business Manager
andy.jarvis@cambridgeshire.gov.uk

Accelerating Achievement

We have recently published an Annual Report of the Accelerating the Achievement of Vulnerable Groups Strategy, 2014-16. Accelerating the achievement of vulnerable groups remains a key priority for the county, during the autumn we will be working to refresh and re-align the strategy in the light of the 2015 results.

The Annual Report is available on the County Council website:
http://www.cambridgeshire.gov.uk/info/20076/children_and_families_practitioners_and_providers_information/370/providing_children_and_families_services/5

Contact: Amanda Phillips, Project Manager
amanda.phillips@cambridgeshire.gov.uk

GCSE results in Cambridgeshire

Provisional figures indicate that Cambridgeshire's GCSE results have improved against the key indicator (5+ GCSE grades A*-C, including English and maths) by 4 percentage points (ppt), to 60%. The percentage of pupils making expected progress in English shows a small decline of just under 1 ppt to 71%. The percentage of pupils making expected progress in Maths shows a 6 ppt rise to 69.8%. The proportion of disadvantaged pupils achieving 5+ GCSE grades A*-C, including English and maths is now 1.5 ppt above last year (32.5% compared to 31%).

Contact: Keith Grimwade, Service Director: Learning
keith.grimwade@cambridgeshire.gov.uk

PUBLIC HEALTH

Changes to the Children's and young people's vaccination programme

HPV Vaccination (Human Papilloma Virus)

This is a national vaccination programme that was introduced some years ago for girls in school year nine, with three doses of the vaccine given over the course of one year. HPV is a causative factor in Cervical Cancer. Uptake has been very good, reaching almost 90% of eligible girls for all three doses in Cambridgeshire, and over 95% for two doses. The programme has been evaluated nationally and evidence from this evaluation has demonstrated that girls achieve an excellent level of immunity after two doses. As a result the programme was reviewed and a decision was made in 2014 to reduce the programme to two doses which, in Cambridgeshire schools, will be given in years eight and nine.

Meningococcus B vaccination

Meningococcus B is one of the bacteria that cause the most severe forms of meningitis and septicaemia (blood infection) and an effective vaccine to prevent this has been sought for many years. An effective vaccine is now available and fully assessed for safety and this vaccine will be introduced into the childhood programme from August 2015. Babies will be offered vaccination at two months, three months and twelve months. There will be a limited catch up programme for all babies born between 1 May 2015 and 30 June 2015. This vaccination will save lives and prevent the serious complications of meningitis.

Meningococcus ACWY vaccine

Vaccination with Meningococcus C vaccine (Men C) has been part of the childhood vaccination programme for many years and has led to a dramatic reduction in cases of meningitis. Men C meningitis was formerly a major cause of meningitis in young people especially those in late teens. Prior to the introduction of Men C vaccination, there were many outbreaks of meningitis especially among 'freshers' in university halls of residence, which resulted in many tragic deaths.

Recently there has been an increase in meningitis cases caused by Meningococcus W, and, as a vaccine was available to prevent Meningococcus strains ACW and Y, this has now been included in the childhood vaccination programme. In this introductory year, catch up doses will be given to those children currently in Years eleven and thirteen – year eleven will be given at school, year thirteen by GPs. The new routine programme from September 2015 will involve vaccinating young people in year nine/ten at school and those who are university 'freshers'. This new programme should further reduce the incidence of cases of Meningitis among young people.

Contact: Dr Linda Sheridan – Interim Consultant Public Health

linda.sheridan@cambridgeshire.gov.uk

Change4life '10 Minute Shake-Up' 2015

Change4Life and Disney have teamed up again this summer to inspire children to do ten minute bursts of moderate to vigorous activity each day. The campaign launched nationally on 2 July 2015 and will run through August 2015, led by Public Health England. Cambridgeshire County Council is promoting the campaign through local pharmacies where families can sign up to receive a free Change4Life Disney activity pack. The packs include a ten Minute Shake-Up team wristband with timer, a Disney team poster and stickers, activity cards, Wild cards, and a very special team move to practice. Children can also team up by joining their favourite Disney Teams: Frozen, Toy Story, Monsters and Big Hero 6 and help their team win by doing as many Shake Ups as they can every day.

In England, 79% of boys and 84% of girls aged five to fifteen do not meet the current physical activity recommendations of sixty minutes each day. The worrying gap between boys and girls' activity levels can be seen from as early as seven years old, which is often attributed to confidence issues and insecurities in body image for young girls. This year's campaign also coincides with new research by British Heart Foundation researchers from the Universities of Oxford and Loughborough, which shows how physical activity can influence children's social and emotional development and increase their confidence and friendships.

Contact: Shaun Birdsall, Health Improvement Specialist
Shaun.Birdsall@cambridgeshire.gov.uk

Department of Health Consultation: Local authority public health allocations 2015/16 in-year savings

On 4 June 2015 the Chancellor of the Exchequer announced a package of savings to be made across government in 2015/16, the current financial year, to reduce public debt. The savings amount to £3 billion and include £200 million from this year's public health grant to local authorities, to be deducted from the January 2016 instalment. For Cambridgeshire the impact of the cut is spread evenly across local authorities, is an in-year cash reduction from the previously announced public health grant of £26,016,000 (including the funding for the transfer of children's public health services age 0-5) to £24,403,000 – a reduction of £1,613,000.

The Department of Health (DH) is running a public consultation, primarily for local authorities, from 31 July 2015 to 28 August 2015, asking the following three questions:

- How should DH spread the £200 million saving across the Local Authorities (LAs) involved?
- How can DH, Public Health England and NHS England help LAs to implement the saving and minimise any possible disruption to services?
- How best can DH assess and understand the impact of the saving?

The consultation is available on
<https://www.gov.uk/government/consultations/local-authority-public-health-allocations-2015-to-2016>

Contact: Dr Liz Robin, Director of Public Health liz.robin@cambridgeshire.gov.uk

Cambridgeshire JSNA: Long Term Conditions across the Lifecourse

A Joint Strategic Needs Assessment (JSNA) on the needs of adults and older people living with Long Term Conditions (LTCs) was approved by Cambridgeshire Health and Wellbeing Board on 2 July 2015. LTCs are health

problems that can't be cured but can be controlled by medication or other therapies. This JSNA is focussed on the management of care for people at higher risk of poor health and social outcomes, such as admission to hospital or increased need for care, particularly people with multiple conditions. Nearly 20% of people aged 18 to 64 years have more than one LTC, this rises to 70% of people over the age of 65. Many people with multiple conditions across all ages experience limitation in their daily lives and substantial numbers experience mental health problems. Services for people with multiple conditions, across all levels of health and social care, are currently not always joined-up.

These findings have clear commissioning and service implications. Services that are built collaboratively with and join-up around, people with LTCs, are fundamental to achieve better integration, communication and improved outcomes for patients, their families and communities. The collated evidence and information in this JSNA may inform the development of effective integrated pathways of care for adults and older people. The report and data supplements are posted on Cambridgeshire Insight.

Contact: Dr Angelique Mavrodaris, Consultant in Public Health
angelique.mavrodaris@cambridgeshire.gov.uk

Public Health Reference Group

The Public Health Reference Group (PHRG) was established in April 2015, reporting to the Health and Well Being Board. Its remit is to provide whole system leadership and multi-agency co-ordination for new public health initiatives in the county and provide access to robust public health evidence for strategic decision makers across the public and community sector in Cambridgeshire and Peterborough. It is co-chaired by the Chief Executive of Fenland District Council and the Director of Public Health, and includes senior representation from the County and all District Councils, the local NHS, Voluntary sector, HealthWatch and the Cambridge University Institute of Public Health.

The PHRG identified physical activity, diet and community engagement with a focus upon health issues as high level priorities for joint action. A Task and Finish Group reviewed the public health evidence base and potential cost effective areas for action and presented to the PHRG in July 2015. The PHRG requested the following areas to be developed into a short term implementation plan

- a. Implementing nutrition policies for early year's centres/nurseries
- b. Workplace health programmes – Local NHS and Councils as employers
- c. Increasing accessibility/community engagement in physical activity programmes in the community (may need pump priming)
- d. Reviewing use of new technologies locally, including self monitoring through mobile apps/pedometers – assess opportunities to link to private sector
- e. Sharing best practice on promoting active travel to work
- f. Working with Uniting Care to raise their awareness of local opportunities for prevention, including physical activity and healthy diet, with the voluntary sector.

Further work will be undertaken to develop a medium to longer term action plan based on the evidence review produced by the Task and Finish Group.

Contact: Val Thomas, Consultant in Public Health
val.thomas@cambridgeshire.gov.uk

Public Health intelligence service: partnership working

Since the appointment of Dr Liz Robin, as Director of Public Health for Peterborough City Council as well as Cambridgeshire County Council, public health analysts across Cambridgeshire and Peterborough Councils have been working together to maximise efficiency. The two public health services have agreed a joint work plan to

provide public health analysis and advice to our local NHS commissioner, Cambridgeshire and Peterborough Clinical Commissioning Group, and will work together on other issues to achieve the most efficient approach. This will include work like the Cambridgeshire New Communities Joint Strategic Needs Assessment and the Peterborough Migrant Worker Joint Strategic Needs Assessment, where there are considerable overlaps in the population groups we are considering. This approach also provides resilience to both Local Authorities in the provision of this specialist Public Health resource.

Contact: David Lea, Assistant Director Public Health Intelligence
david.lea@cambridgeshire.gov.uk

CUSTOMER SERVICE AND TRANSFORMATION

Devolution – decentralisation of powers to Local Government

Devolution ask

Secretary of State for Communities and Local Government Greg Clark has responded to a Devolution Deal request letter from all the Cambridgeshire County and District Councils, Greater Cambridge and Greater Peterborough LEP and public service bodies in Cambridgeshire and Peterborough suggesting we begin discussions with officials. Officers from Cambridgeshire and Peterborough organisations have set up a group to co-ordinate work to refine and flesh out our devolution proposals in greater detail. Areas where devolution is being sought include economic growth, health and social care, public safety and legislation and regulation.

Governance Review

To support our devolution ask organisations in Cambridgeshire and Peterborough have commissioned ResPublica to conduct an independent review of governance arrangements in the area to consider what kind of arrangements might best enable devolved powers to be managed effectively and decisively. Options that will be considered include different geographies of Combined Authority, District Unitaries and comparison with the Directly-Elected Mayor model (which has been ruled out). The review has now started and should be completed by the Autumn.

Contact: Kevin Hocter, Policy and Project Officer
Kevin.Hocter@cambridgeshire.gov.uk

The Lister Wilson Wings of Time Flight Raffle

A flight over Cambridge is being offered for the price of a £5 raffle ticket after qualified pilot Councillor Paul Bullen decided he would like to raise funds for Arthur Rank Hospice Charity in memory of former County Councillor Lister Wilson who died in the Hospice.

The raffle tickets can be obtained from the hospice on Mill Road, one of the charity's three shops, or from the council offices at Shire Hall. For more information about the raffle or to obtain tickets, please call 01223 723115 or see the Arthur Rank Hospice Charity website: <http://www.arhc.org.uk/event.asp?§=1542&o=2>

Contact: Julia Pettit, Business Support Officer, Customer Service and Transformation
Julia.pettit@cambridgeshire.gov.uk

UPCOMING MEETINGS

COUNCIL AND ASSOCIATED MEETINGS OPEN TO THE PUBLIC IN SEPTEMBER 2015

Members of the public are welcome at the following meetings. Please note that this list is in draft and is subject to change.

DATE	TIME	MEETING	VENUE
3 rd	2.00 pm	Health Committee	Shire Hall, Cambridge
8 th	10.00 am	Economy and Environment Committee	Shire Hall, Cambridge
8 th	2.00 pm	Children and Young People Committee	Shire Hall, Cambridge
10 th	10.00 am	Planning Committee	Shire Hall, Cambridge
10 th	2.00 pm	LGSS Joint Committee (reserve date)	to be confirmed
15 th	10.00 am	General Purposes Committee	Shire Hall, Cambridge
15 th	2.00 pm	Constitution and Ethics Committee	Shire Hall, Cambridge
17 th	10.00 am	Health and Wellbeing Board	Bargroves Centre, St Neots PE19 2EY
17 th	10.00 am	Pension Fund Board Investment Sub-Committee	Shire Hall, Cambridge
22 nd	10.00 am	Highways and Community Infrastructure Committee	Shire Hall, Cambridge
22 nd	2.00 pm	Audit and Accounts Committee	Shire Hall, Cambridge
29 th	2.00 pm	Adults Committee	Shire Hall, Cambridge
30 th	2.00 pm	Northstowe Joint Development Control Committee	Council Chamber, South Cambridgeshire Hall, Cambourne

- * Meeting will move into private session if it becomes necessary to consider exempt information [information relating to any individual])

All or part of these meetings are likely to be held in private on the grounds that they are considering exempt information under Part 1 of Schedule 12A of the Local Government Act as amended, and that it would not be in the public interest for this information to be disclosed.

DATE	TIME	MEETING	VENUE
8 th	10.00 am	Service Appeals Sub-Committee [information relating to any individual] (provisional)	Cambridge or March
23 rd	2.00 pm	Staffing and Appeals Committee	Shire Hall, Cambridge
24 th	10.00 am	Service Appeals Sub-Committee [information relating to any individual] (provisional)	Cambridge or March

As Your County Councillor I welcome hearing from you on these and/or any other issues that affect our community.

County Councillor Adrian Dent

May 5th 2015

Tel: 01763 245669

Mob: 07834801736

Email : adrian.dent@cambridgeshire.gov.uk

Twitter: @adrianeident

www.adrianeident.org.uk

NALC – FINANCIAL REGULATIONS

It is proposed that the the draft regulations be adopted, subject to the following comments/decisions:

Note that the Clerk has been appointed as RFO (Responsible Financial Officer).

Note that where amounts in the draft regulations may be varied by the PC, these are listed below, for agreement by the PC.

1.13 The PC cannot delegate the approval of accounting statements. (are the annual accounts approved by the PC before presentation to the Annual Parish Meeting?)

1.14 The PC must approve any grant or single commitment > £5,000 (confirm amount – (change to all commitments as PC authorises all?))

2.2 Re verification of bank reconciliations – remove from draft ‘or a cheque signatory’

3.3 This section concerns 3 year forecasts of revenue and capital receipts and payments. We would be required to do these.

4.1 The PC may authorise revenue expenditure for all items > £5,000; a delegated committee for items > £500 and Clerk + Chairman < £500. (Remove as PC authorises all payments, except for emergencies, see below)

4.5 The Clerk may in emergencies approve expenditure < £500 (confirm amount).

The Clerk together with the Chairman may in emergencies approve expenditure < £1,000 (confirm amount).

4.8 Quarterly explanations of material variances vs budget. Material is £100 or 15% of budget. Confirm amount.

5.1 Remove ‘The PC shall seek credit references in respect of members or employees who act as bank signatories’.

5.5 The Clerk/RFO to have authority to authorise fund transfers within our banking arrangements < £10,000 (confirm amount).

6.4 Note that PCs must consider Standing Orders if they have a ‘disclosable pecuniary interest or any other interest’ when signing cheques.

6.11 Section to be reworded re PINs for access to the PCs records on computers.

8.3 The council's bank statements to be sent to the Chairman at the same time as they are issued to the Clerk/RFO (delete)

9.3 The PC will review all fees and charges at least annually, following a report of the Clerk (confirm that we do).

11.1b Tenders required for contracts > £2,000 (subject to exceptions). (confirm amount)

11.1h Re contracts < £2,000 and > £500, 3 quotations required; Contracts < £500 Clerk to strive to obtain 3 estimates or 1 quotation (subject to exceptions). Confirm agreement and amounts).

14.2 No purchase, sale or disposal of assets < £250 without authority of PC. (? agreement and amount).

14.5 Full business case required for purchase, sale or disposal of assets (subject to 14.2). Confirm.

Notes. Above values should be reviewed regularly and confirmed annually by the PC.

GULDEN MORDEN PARISH COUNCIL FINANCIAL STATEMENT

Sep-15

Summary of Month

£

Balance brought forward

103,182.67

Adjustments/Corrections

Expenditure approved at last/between meetings

JEWSON BUILDING SUPPLIES -28.66

Receipts

JEREMY RULE G22 WATTS 225.00

HMRC VAT 6496.00

Total Adjustments 6692.34

Balance revised after adjustments **109875.01**

Bank Reconciliation

Account	Funds	Statement	Outstanding
Barclays Community Account	42,302.30	41,100.96	1,201.34
Barclays Tracker Account	16,915.59	16,915.59	
Cambridge & Counties Account	50,657.12	50,657.12	
Total	109,875.01	108,673.67	1,201.34

Expenditure for approval at meeting

£

Chq #

CARTER JONAS	CRAFT RENT	350.00	2079
RS MEMORIALS	MAKE SAFE MEMORIALS	90.00	2080
TOWN AND COUNTRY	TREE WORKS	367.20	2081
RPM	PLAY EQUIPMENT REPAIRS	1020.00	2082
VILLAGE HALL	ROOM HIRE	42.00	2083
BUCHANS	GRASSCUTTING	1581.60	2084
BUCHANS	GRASSCUTTING	552.00	2085
CAME AND CO	INSURANCE	620.04	2086
	SALARY	193.32	2087
	SALARY	193.52	2088
HMRC	PAYE/NIC	18.80	2089

Total 5028.48

Balance C/F **104,846.53**

Gail Stoehr
Responsible Financial Officer

Notes:

Late invoices will be brought to the meeting

GILDEN MORDEN PARISH COUNCIL

Small Grant Scheme Application Form

DETAILS OF GRANT APPLIED FOR :		
1	What do you want to use the grant for?	
2	Who will benefit from the work or activity?	
3	How much is required to pay for this?	
4	How much would you like the Council to provide?	
5	How will you raise any difference?	
DETAILS OF GROUP OR ORGANISATION :		
6	Name of organisation or group applying	
7	Are you a new group in the process of being formed?	Yes No
8	If No - when were you established?	
9	If No – are you a Registered Charity?	Yes No
10	If Yes – what is your registration number?	
11	Do you have a bank account?	Yes No <i>If yes please supply a copy of your latest statement</i>
12	Do you have published accounts?	Yes No <i>If yes please supply a copy of your latest accounts</i>
13	Do you have a constitution? Yes or No	Yes No <i>If yes please supply a copy of your constitution</i>
14	What are the objectives of the group or organisation?	

This grant aid application should be signed by two members of your Organisation's Committee, one of whom must be the Chairman, Secretary or Treasurer.

We confirm that the information given in this application is accurate and that the Organisation undertakes to inform Council of any changes in the Organisation's circumstances that would affect this application. We also confirm that any grant awarded by the Council will be spent only on the purpose for which it was given.

Signed.....

Signed.....

Position.....

Position.....

Date.....

Date.....

The signing and submission of this form constitutes acceptance of the terms and conditions overleaf

Terms and conditions of the grant

1. Grants **can be awarded to** voluntary groups, societies, clubs, not-for-profit organisations or charities operating in the Parish area where the benefit will be predominately for the residents of the Parish area.
2. Grants **will not be awarded to** individuals. (minimum 2 or more unrelated individuals)
3. Grants to regional or national charities **will only be considered** where a specific project will deliver obvious benefits to residents in the Parish area.
4. The amount of any grant award will be at the discretion of the Council
5. All applications will be considered on their merits, but in general grants can be awarded for:
 - o Capital Projects such as purchase of equipment, works to buildings, improvements to premises, improvement to the local environment
 - o Revenue Projects such as a Community Event, Festivals or other Special Events where grants towards running costs, salaries, consumables, insurance or training may be considered
6. The purpose for which any grant is made must be in the interest of the Parish area or any part of it or all or some of the inhabitants of the Parish area which is defined by the boundaries of the Parish Council.
7. The amount of expenditure must be commensurate with the benefit to the inhabitants of the area.
8. Groups from outside the Parish who can demonstrate direct benefit to the area are eligible to apply for a grant.
9. The Council may take into account any previous grant made to an organisation or group when considering a new application
10. No grant will be awarded to or for any commercial venture for private gain.
11. Retrospective applications will not be funded where the expenditure had been made, the project has been carried out or the event has taken place.
12. All grants will be conditional upon submission of a Small Grant Application Form.
13. All grant recipients are required to provide the Council with a brief report, including photographs where appropriate, of how the grant has been utilised, how it has assisted the organisation or group and what it has achieved. This must be submitted within 3 months of the purchase of the capital equipment or completion of the project.
14. If the grant is put to purposes other than those for which it was awarded without the prior approval of the Council, the recipient organisation or group will be required to repay the grant to the Council.
15. The organisation or group should supply such information as the Council may request regarding the impact of the project on the Council's area.
16. Recognition of the grant from the Council must be made in any publicity issued by the receiving body.

How will a grant application be assessed?

- o Does the Council have the powers to provide a grant for the project outlined?
- o How well does the grant meet the needs of the community in providing positive benefit to residents?
- o How effectively will the group use the grant?
- o Is the cost of the project appropriate?
- o Are the expected outcomes realistic?
- o What level of contributions has been, or will be, raised locally?
- o Can the organisation or group reasonably be expected to obtain sufficient funding from another, perhaps more appropriate, sources?
- o How is the organisation or group managed and does it have a constitution?

The grant application form should be returned to the Parish Clerk

FOR COUNCIL USE ONLY

<i>Application Number</i>	
<i>Date Received</i>	
<i>Delete as appropriate</i>	<i>Approved or Declined</i>
<i>Date</i>	
<i>Amount Approved</i>	
<i>Date Funds Issued to Group</i>	
<i>Transaction Reference</i>	

**HIBBITT & SONS
MASONRY LTD**

**Monumental Sculptors & General Masons
126. Victoria Road
Cambridge
CB4 3DZ**

**Tel. 01223 354556 Fax. 01223 462978
Email: joan@hibbittmasonry.co.uk**

To:

Applicant

Mrs L G Stoehr
30. West Drive
Highfields
Caldecote
Cambridge
CB3 7NY

Mrs Margaret Cooper
Flat 2 Dunkerley Court
Birds Hill
Letchworth
Herts
SG6 1FE

Dear Sir/Madam

Date 15th July 2015

Please approve New Memorial

PLEASE ADVISE FEE: £ :

To be erected in:- Guilden Morden Cemetery

New Memorial

Inscription

Yorkstone Flat Tablet

**BABY ELLIS
3.12.1948
REMEMBERED
BY ALL
THE FAMILY**

15" x 12"

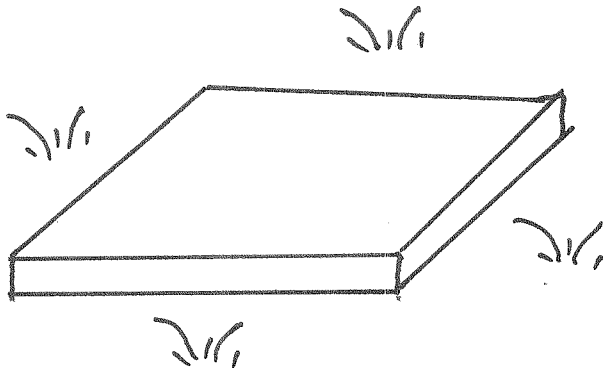

Yours faithfully

M. L. Hibbitt

Hibbitt & Sons

Order No: CM 1507:5920

Approved by.....
(For Council use only)

Dated.....